

51 SERIES B-BLUE

AMAZON

SINGLE STACK HOUSING FOR B-BLUE FILTERS





The **51 SERIES** single cartridge housing range is renowned for its high quality design and manufacture. These housings are designed to accept large diameter pleated and depth media **B-BLUE** cartridges. They are fitted with a Vee clamp closure and are suitable for a wide variety of liquid and gas filtration applications.

The **51 SERIES** housing will accept the full range of Amazon **B-BLUE** cartridges with removal ratings ranging from 0.5 to 150µm and with nominal lengths of 10" and 20".

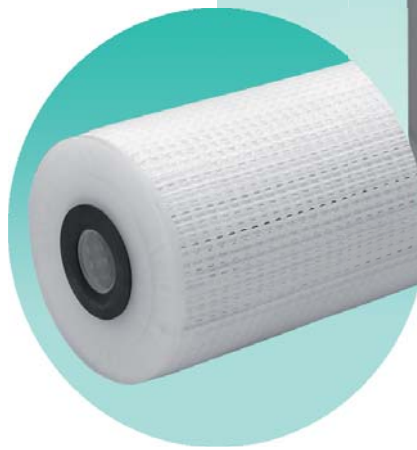
Product Features:

- Quick release Vee Clamp Closure for easy opening
- Lightweight, high specification design
- Dual purpose head accepts SOE code 3 and DOE cartridges
- Suitable for either 10" or 20" cartridges
- Available in 316L stainless steel
- Wide range of inlet/outlet connection size and types available
- PED Compliant to Sound Engineering Practice
- Full traceability on all parts, material certification packs available
- Rated at 10 bar liquid, 6 bar Gas



Accessories	Part Number
Pressure Gauge and Vent Valve Kit 	60S000016
Ball Valve and Nipple 	60S000010
Stand 	50S010012
Mounting Bracket 	56S000001

51 SERIES B-BLUE FEATURES AND BENEFITS

- Investment Cast head (avoids the porosity & inclusion problems associated with lower quality sand castings)
- Integral vent and drain sockets to aid efficient filter change-out
- Unique interchangeable configuration enables choice of SOE or DOE cartridge styles in the same housing
- Every housing is etched with a batch number for full traceability
- Full housing customisation service available
- High specification bead blast finish
- Fully traceable 316L stainless steel construction

51 SERIES B-BLUE

TECHNICAL DATA

Maximum Operating Conditions

Maximum Pressure: Liquid: 10 Bar g
Gas: 6 Bar g

Maximum Temperature: 110°C

Materials of Construction

Body and Closure: 316L St.Steel
Clamp: 304 St.Steel

Finish

Vessel: Bead blast

Connections

Inlet/Outlet: 1" BSPF
Vent: 1/4" BSPF with Plug
Drain: 1/4" BSPF with Plug

Model	Dimensions					Volume (Litres)	Dry Weight
	A	B	C	D	E		
510110VN10B1BEBB	417	-	-	120	320	4.2	4.4 kgs
510120VN10B1BEBB	671.5	-	-	120	574	7.3	6 kgs

PED Status:

Fluid Groups:

Compliant with 97/23/EC

Gas Group 2

Liquids Group 1 + 2

Marking:

(SEP) Sound Engineering Practice

Exceptions:

Group 1 liquids - Explosive

ATEX:

Compliant 94/9/EC, level CE Ex II 2 GD c X

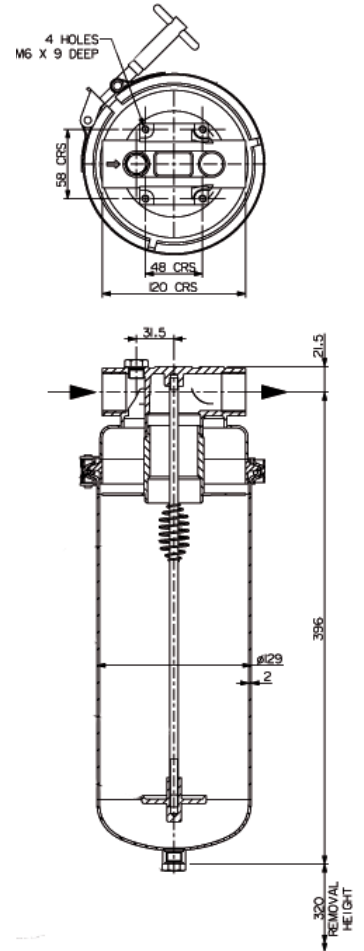

AMAZON FILTERS LTD.

ALBANY PARK ESTATE, FRIMLEY ROAD,
CAMBERLEY, SURREY, GU16 7PG
ENGLAND

Tel: +44 (0) 1276 670 600

Fax: +44 (0) 1276 670 101

Email: sales@amazonfilters.co.uk

Web: www.amazonfilters.co.uk



Certificate No. FM39584

Distributed by: