

51 SERIES



SINGLE STACK FILTER HOUSING





The **51 SERIES** single cartridge housing is renowned for its high quality design and manufacture. With the ability to accept both standard Double Open End and Single Open End cartridges, this single stack housing with Vee clamp closure has proved very successful in a wide variety of applications within the liquids processing industry.

The **51 SERIES** will accept the full range of Amazon and industry standard cartridges ranging from 0.1 to 500µm with nominal lengths of 5, 10, 20 and 30".

Product Features:

- Quick release Vee Clamp Closure for easy opening
- Lightweight, high specification investment cast head
- Easy to use tie rod assembly design ensures cartridge centralisation (for a reliable knife edge seal) that enables the use of either 9.75" or 10" cartridge length configurations (or multiples) in the same housing
- Dual purpose head accepts SOE code 3 and DOE cartridges
- SOE code 7 and code B adaptors available
- Available in 316L stainless steel or Hastelloy C22 for maximum compatibility
- Wide range of connection size and types, cartridge lengths and materials of construction
- PED Compliant to Sound Engineering Practice
- Full traceability on all parts, material certification packs available
- Rated at 10 bar liquid, 6 bar Gas



Accessories	Part Number
Pressure Gauge and Vent Valve Kit 	60S000016
Ball Valve and Nipple 	60S000010
Stand 	50S010012
Mounting Bracket 	50S010003

51 SERIES FEATURES AND BENEFITS

- Investment Cast head (avoids the porosity & inclusion problems associated with lower quality sand castings)
- Integral vent and drain sockets to aid efficient filter changeout complete with PTFE washer
- Unique interchangeable configuration enables choice of SOE or DOE cartridge styles in the same housing
- Every housing is etched with a serial number for full traceability
- Full housing customisation service available
- Available in both 316L Stainless Steel and C22 Hastelloy

51 SERIES

TECHNICAL DATA

Maximum Operating Conditions

Maximum Pressure: Liquid: 10 Bar g
Gas: 6 Bar g
Maximum Temperature: 110°C

Materials of Construction

Body and Closure: 316L St. Steel
Hastelloy C22
Clamp: 304 St. Steel
Seal: Ethylene Propylene

Finish

Vessel: Externally polished sump, bead blast head

Connections

Inlet/Outlet: 1" BSPF
Vent: 1/4" BSPF with Plug
Drain: 1/4" BSPF with Plug

Model	Dimensions					Volume (Litres)	Dry Weight
	A	B	C	D	E		
5"	214	-	-	120	173	1.5	2.0
10"	341	-	-	120	300	2.2	2.6
20"	595	-	-	120	554	3.7	3.6
30"	849	-	-	120	808	5.2	4.6

PED Status: Compliant with 97/23/EC
Fluid Groups: Gas Group 2
Liquids Group 1 + 2
Marking: (SEP) Sound Engineering Practice
Exceptions: Group 1 liquids - Explosive
ATEX: Compliant 94/9/EC, level CE Ex II 2 GD c X

Technical drawings for each housing showing dimensions, volume and weights available on request.

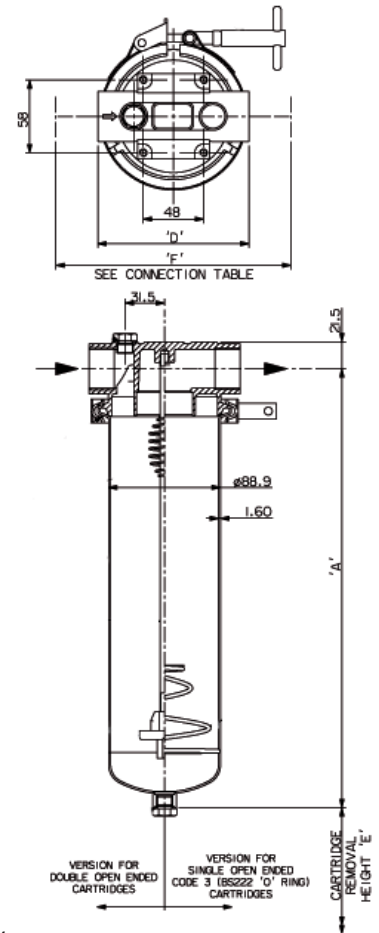

AMAZON FILTERS LTD.

ALBANY PARK ESTATE, FRIMLEY ROAD,
CAMBERLEY, SURREY, GU16 7PG
ENGLAND

Tel: +44 (0) 1276 670 600

Fax: +44 (0) 1276 670 101

Email: sales@amazonfilters.co.uk

Web: www.amazonfilters.co.uk



Certificate No. FM39584

Distributed by: