

53 SERIES



SINGLE STACK FILTER HOUSING





The **53 SERIES** single cartridge housing is ideal for use in sensitive gas, steam and pulsating pressure environments. With the ability to accept both standard Double Open End and Single Open End cartridges, this single stack housing uses a DIN threaded closure that has proved successful in a wide variety of applications such as aerosol filling lines and nitrogen purge systems for beverage and pharmaceutical applications.

The **53 SERIES** will accept the full range of Amazon and industry standard cartridges ranging from 0.1 to 500µm with nominal lengths of 5, 10, 20 and 30".

Product Features:

- DIN threaded closure allows higher operating pressures
- Suitable for gas, steam, and pulsating pressure environments
- Lightweight, high specification investment cast head and top ring
- Easy to use tie rod assembly ensures cartridge centralisation (for a reliable knife edge seal) that enables the use of either 9.75" or 10" cartridge length configurations (or multiples) in the same housing.
- Dual purpose head accepts SOE code 3 and DOE cartridges
- SOE code 7 and code B adaptors available
- Available in 316L stainless steel or Hastelloy C22 for maximum compatibility
- Wide range of connection size and types, cartridge lengths and materials of construction.
- PED Compliant to Cat I
- Full traceability on all parts, material certification packs available
- Rated at 28 bar



Accessories	Part Number
Pressure Gauge and Vent Valve Kit 	53S010003
Ball Valve and Nipple 	60S000010
Stand 	50S010012
Mounting Bracket 	50S010003

53 SERIES FEATURES AND BENEFITS

- Investment Cast head (avoids the porosity & inclusion problems associated with lower quality sand castings)
- Integral vent and drain sockets to aid efficient filter changeout complete with PTFE washer
- Unique interchangeable configuration enables choice of plug in or DOE cartridge styles in the same housing
- Every housing is etched with a serial number for full traceability
- Full housing customisation service available
- Available in both 316L Stainless Steel and C22 Hastelloy

53 SERIES

TECHNICAL DATA

Maximum Operating Conditions

Maximum Pressure: Liquid: 28 Bar g
Gas: 28 Bar g
Maximum Temperature: 150°C

Materials of Construction

Body and Closure: 316L St. Steel
Hastelloy C22
Seal: Viton

Finish

Vessel: Externally polished sump, bead blast head

Connections

Inlet/Outlet: 1" BSPF
Vent: 1/4" BSPF with Plug
Drain: 1/4" BSPF with Plug

Model	Dimensions					Volume (Litres)	Dry Weight
	A	B	C	D	E		
10"	341	-	-	120	300	2.2	3.0
20"	595	-	-	120	554	3.7	4.0
30"	849	-	-	120	808	5.2	5.0

PED Status:

Fluid Groups: Compliant with 97/23/EC
Gas Group 2
Liquids Group 1 + 2

Marking:

Exceptions: CE

ATEX: Compliant 94/9/EC, level CE Ex II 2 GD c X

Technical drawings for each housing showing dimensions, volume and weights available on request.

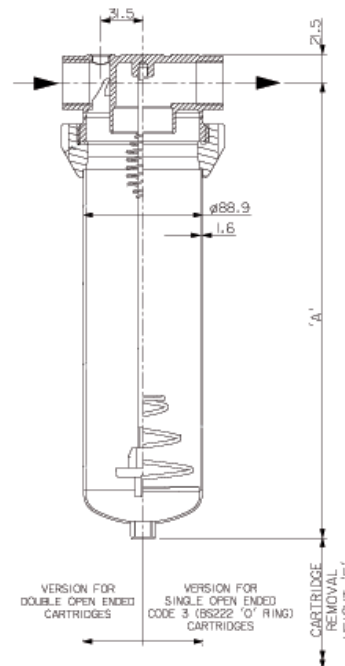
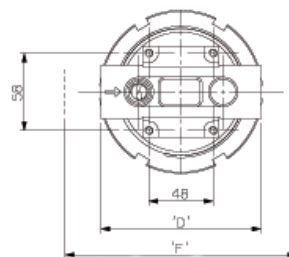

AMAZON FILTERS LTD.

ALBANY PARK ESTATE, FRIMLEY ROAD,
CAMBERLEY, SURREY, GU16 7PG
ENGLAND

Tel: +44 (0) 1276 670 600

Fax: +44 (0) 1276 670 101

Email: sales@amazonfilters.co.uk

Web: www.amazonfilters.co.uk



Certificate No. FM39584

Distributed by: