

54 SERIES



SINGLE STACK FILTER HOUSING

The **CLEARVIEW** single cartridge housing is unique with its special clear bowl section for viewing the condition of the filter element.

Designed specifically for use in the Fine Chemicals and Pharmaceutical industries, the **CLEARVIEW** has proved to be highly successful where fluid cleanliness requires visual monitoring online.

Materials of construction are either 316L or Hastelloy C22 for all metallic parts, whilst the unique clear screen utilises a Borosilicate tube for maximum fluid compatibility. Seal materials are offered in EPDM, Viton, Silicone and encapsulated FEP.





When used in conjunction with the Amazon ceramic solids retaining screen, it proves to be the optimum choice for users of catalyst reaction vessels and powder filters where any breakthrough can be clearly seen on the retaining screen. Replacing more conventional glass bodied assemblies (which can be notoriously difficult to work with) the **CLEARVIEW**, with its easy to use cast Vee clamp closure, has proved highly successful with operators and engineers alike.

The **CLEARVIEW** will accept the full range of Amazon and industry standard cartridges ranging from 0.1 to 500µm with nominal lengths of 10, 20 and 30".

Product Features:

- Quick release cast Vee Clamp Closure for easy opening
- Lightweight, high specification investment cast head
- Unique clear bowl assembly for reviewing cartridge or screen condition
- Easy to use tie rod assembly design ensures cartridge centralisation (for a reliable knife edge seal) that enables the use of either 9.75" or 10" cartridge length configurations (or multiples) in the same housing
- Dual purpose head accepts SOE code 3 and DOE cartridges
- SOE code 7 and code B adaptors available
- Wide range of connection size and types, cartridge lengths and materials of construction.
- PED Compliant to Sound Engineering Practice
- Full traceability on all parts, material certification packs available
- Rated at FV/10 bar



Accessories	Part Number
Pressure Gauge and Vent Valve Kit 	60S000016
Ball Valve and Nipple 	60S000010
Stand 	50S010012
Mounting Bracket 	50S010003

54 SERIES FEATURES AND BENEFITS

- Investment Cast head (avoids the porosity & inclusion problems associated with lower quality sand castings)
- Integral vent and drain sockets to aid efficient filter changeout complete with PTFE washer
- Unique interchangeable configuration enables choice of plug in or DOE cartridge styles in the same housing
- Every housing is etched with a serial number for full traceability
- Full housing customisation service available
- Available in both 316L Stainless Steel and C22 Hastelloy

54 SERIES

TECHNICAL DATA

Maximum Operating Conditions

Maximum Pressure: Liquid: 10 Bar g F/V
Gas: N/A
Maximum Temperature: 110°C

Materials of Construction

Body and Closure: 316L St. Steel
Hastelloy C22
Clamp: 304 St. Steel
Seal: EPDM
Retaining Glass: Borosilicate with Acrylic safety shield and PTFE Seals

Finish

Vessel: Externally polished sump, bead blast head

Connections

Inlet/Outlet: 1" BSPF
Vent: 1/4" BSPF with Plug
Drain: 1/4" BSPF with Plug

Model	Dimensions					Volume (Litres)	Dry Weight
	A	B	C	D	E		
10"	341	-	-	120	300	2.2	6.1
20"	595	-	-	120	554	3.7	7.1
30"	849	-	-	120	808	5.2	8.1

PED Status:

Fluid Groups: Compliant with 97/23/EC
Liquids Group 1 + 2
Marking: (SEP) Sound Engineering Practice
Exceptions: Group 1 liquids - Explosive
ATEX: Compliant 94/9/EC, level CE Ex II 2 GD c X

Technical drawings for each housing showing dimensions, volume and weights available on request.

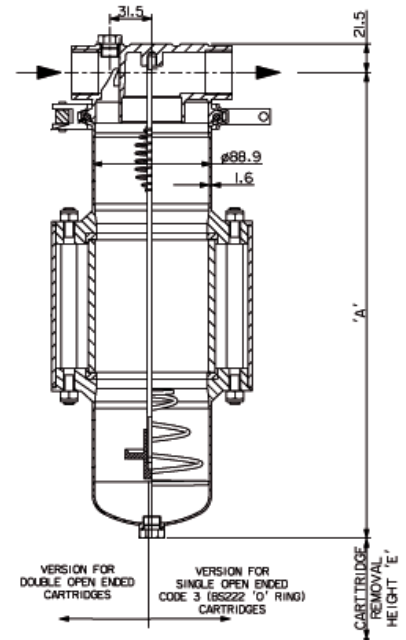
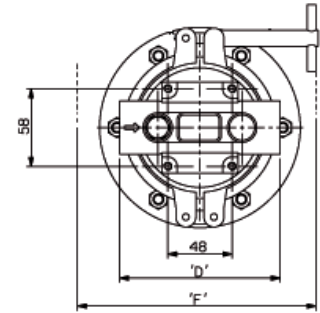

AMAZON FILTERS LTD.

ALBANY PARK ESTATE, FRIMLEY ROAD,
CAMBERLEY, SURREY, GU16 7PG
ENGLAND

Tel: +44 (0) 1276 670 600

Fax: +44 (0) 1276 670 101

Email: sales@amazonfilters.co.uk

Web: www.amazonfilters.co.uk



Certificate No. FM39584

Distributed by: