

# 55 SERIES





## SINGLE STACK FILTER HOUSING

The **55 SERIES** single cartridge housing has been developed specifically for environments where access to the filter chamber is restricted. This unit accepts Double Open End cartridges, and uses a central bolt with Tee nut for the closure. Ideal for use in areas of limited access and where the spent fluid and element need to be retained within the bowl. Suitable only for use in the liquids processing industry.

### Product Features:

- Through bolt assembly ensures centralisation of the cartridge for a reliable knife edge seal, suitable for cartridges ranging from 9.75" through to 30".
- Lightweight, high specification investment cast head
- Available in 316L stainless steel
- Wide range of connection size and types, cartridge lengths and materials of construction.
- PED Compliant to Sound Engineering Practice
- Full traceability on all parts, material certification packs available
- Rated at 10 bar



Accessories	Part Number
Pressure Gauge and Vent Valve Kit 	60S000016
Ball Valve and Nipple 	60S000010
Mounting Bracket 	50S010003

## 55 SERIES FEATURES AND BENEFITS

- Investment Cast head (avoids the porosity & inclusion problems associated with lower quality sand castings)
- Integral vent and drain sockets to aid efficient filter changeout complete with PTFE washer
- Every housing is etched with a serial number for full traceability
- Full housing customisation service available

55 SERIES

## TECHNICAL DATA

### Maximum Operating Conditions

Maximum Pressure: Liquid: 10 Bar g  
Gas: N/A  
Maximum Temperature: 110°C

### Materials of Construction

Body and Closure: 316L St. Steel  
Seal: EPDM

### Finish

Vessel: Bead Blast all over

### Connections

Inlet/Outlet: 1" BSPF  
Vent: 1/4" BSPF with Plug  
Drain: 1/4" BSPF with Plug

Model	Dimensions					Volume (Litres)	Dry Weight
	A	B	C	D	E		
10"	319	-	-	120	100	1.8	2.6
20"	573	-	-	120	100	3.3	3.9
30"	827	-	-	120	100	4.8	5.2

### PED Status:

Compliant with 97/23/EC  
Fluid Groups: Liquids Group 1 + 2  
Marking: (SEP) Sound Engineering Practice  
Exceptions: Group 1 liquids - Explosive  
ATEX: Compliant 94/9/EC, level CE Ex II 2 GD c X

Technical drawings for each housing showing dimensions, volume and weights available on request.

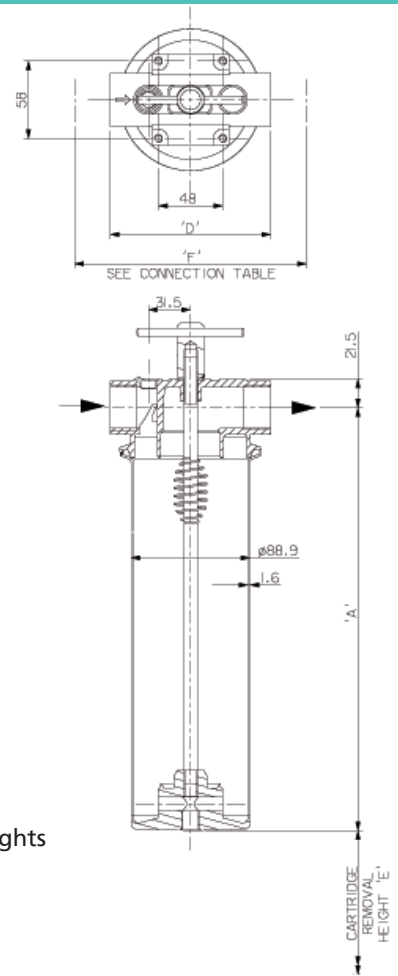

## AMAZON FILTERS LTD.

ALBANY PARK ESTATE, FRIMLEY ROAD,  
CAMBERLEY, SURREY, GU16 7PG  
ENGLAND

Tel: +44 (0) 1276 670 600

Fax: +44 (0) 1276 670 101

Email: sales@amazonfilters.co.uk

Web: www.amazonfilters.co.uk



Certificate No. FM39584

Distributed by: