

# 56 SERIES

**AMAZON**

## SINGLE STACK FILTER HOUSING

The **56 SERIES** single cartridge housing is renowned for its high quality design and manufacture and accepts both standard Double Open End and Single Open End cartridges. The housing has a high security bolted closure and is particularly suitable for hazardous liquid and gas applications.

The **56 SERIES** will accept the full range of Amazon and industry standard cartridges ranging from 0.1 to 500µm with nominal lengths of 5, 10, 20 and 30".

Product Features:

- High security bolted closure suitable for hazardous applications
- Dual purpose head accepts SOE code 3 and DOE cartridges
- SOE code 7 and code B adaptors available
- Offered with a wide range of connection sizes and types
- Available for a range of cartridge lengths
- PED and ATEX Compliant
- Full traceability on all parts, material certification packs available
- Rated at 10 bar and full vacuum in liquids
- Rated at 9 bar and full vacuum in gases



## 56 SERIES FEATURES AND BENEFITS

- Bolted closure provides high security housing sealing
- Suitable for hazardous liquid and gas applications
- Full vacuum rating in liquids and gases
- Integral vent and drain sockets to aid efficient filter change-out complete with PTFE washer
- Unique interchangeable configuration enables choice of SOE or DOE cartridge styles in the same housing
- Every housing is etched with a serial number for full traceability
- Full housing customisation service available

56 SERIES

## TECHNICAL DATA

### Maximum Operating Conditions

Maximum Pressure: Liquid: 10 Bar g and full vacuum  
Gas: 9 Bar g and full vacuum  
Maximum Temperature: 150°C

### Materials of Construction

Body and Closure: 316L St. Steel  
Hastelloy C22  
Seal: Ethylene Propylene

### Finish

Vessel: Externally polished sump, electropolished head

### Connections

Inlet/Outlet: 1" BSPF  
Vent: 1/4" BSPF with Plug  
Drain: 1/4" BSPF with Plug

Model	Dimensions					Volume (Litres)	Dry Weight
	A	B	C	D	E		
10"	343	-	-	120	300	2.2	7.2
20"	597	-	-	120	554	3.8	8.2
30"	851	-	-	120	808	5.2	9.2

**PED Status:** Compliant with 97/23/EC

Fluid Groups: Gas Group 1 + 2  
Liquids Group 1 + 2

Marking: CE Marked

Exceptions: Group 1 liquids - Explosive

ATEX: Compliant 94/9/EC, level CE Ex II 2 GD c X

Technical drawings for each housing showing dimensions, volume and weights available on request.

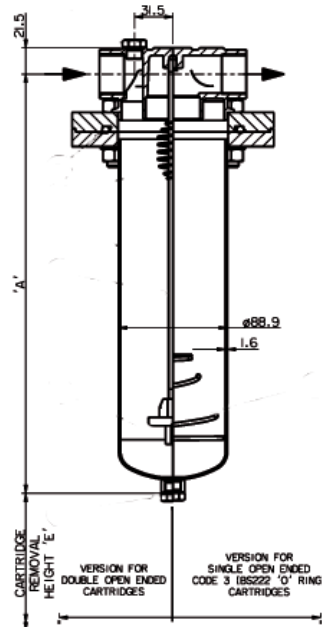
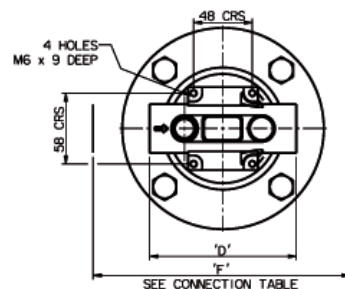

## AMAZON FILTERS LTD.

ALBANY PARK ESTATE, FRIMLEY ROAD,  
CAMBERLEY, SURREY, GU16 7PG  
ENGLAND

Tel: +44 (0) 1276 670 600

Fax: +44 (0) 1276 670 101

Email: [sales@amazonfilters.co.uk](mailto:sales@amazonfilters.co.uk)

Web: [www.amazonfilters.co.uk](http://www.amazonfilters.co.uk)



Certificate No. FM39584

Distributed by: