

64 SERIES

AMAZON

MULTI STACK FILTER HOUSING

The **64 SERIES** Multi cartridge housing is designed to accommodate 3, 5, 10 or 15 stacks of filters up to 40" long. The centre positioned, split shell opening style is equipped with a Cast Vee clamp as standard for pressures ranging from 6 - 10 bar.g. Leg mounted with the split shell opening, this is the ideal choice when using Single Open End plug in style cartridges. The simple to lift off lightweight dome allows full and easy access to the cartridges for rapid changeouts. With the free draining clean chamber, the **64 SERIES** housings suit processes where cleanliness and ease of operation are essential. Accepting both standard Double Open End and Single Open End cartridges, this leg mounted, free standing housing will suit most applications. Bolted closures are an option available for all models.

The **64 SERIES** will accept the full range of Amazon and industry standard cartridges with nominal lengths of 20, 30 and 40".

Product Features:

- Split body design allows easy access to cartridges on changeout
- Dished bottom end allows complete drainage of clean chamber, leading to improved system cleanliness
- Adjustable strap legs allow the user to set inlet and outlet heights
- Vee clamp closures use unique 'W' style seal for reliable leak free operation
- High quality cast Vee clamps for safety and security
- Cast compression nut with integral PTFE washer for easy, hand tight cartridge sealing
- Wide range of connection sizes and types available
- Universal cup allows the use of plug in (Code 3, Code 8 and Code A) and DOE cartridge styles in the same housing
- PED and ATEX Compliant



Accessories

Pressure Gauge and Vent Valve Kit



Pressure Gauge and Auto Vent Valve Kit



Ball Valve and Nipple



64 SERIES FEATURES AND BENEFITS

- Large selection of housing sizes available so suitable for a wide range of processes
- Integral vent, clean and dirt drains to aid efficient filter changeout
- Each housing hydrostatically pressure tested
- Internally and externally electropolished as standard
- Each housing etched with a unique serial number for full traceability
- Full housing customisation service available
- Universal cup allows the use of plug in (Code 3, Code 8 & Code A) or DOE cartridge styles in the same housing

64 SERIES

TECHNICAL DATA

Max Operating Conditions	6403	6405	6410	6415
Vee Clamp:	10 Bar g	10 Bar g	8.5 Bar g	6 Bar g
Bolted Closure:	10 Bar g	10 Bar g	10 Bar g	10 Bar g
Gas:	6 Bar g	4.5 Bar g	N/A	N/A
Maximum Temperature:	110°C	110°C	110°C	110°C

Materials of Construction

Body: 316L St.Steel
 Closure: Vee Clamp - 304 St.Steel
 Screw Clamp - Zinc Plated carbon steel (Optional stainless steel)
 Vessel Finish: Electropolished

Connections

	6403-05	6410	6415
Inlet/Outlet:	2" BSPM	3" Flange	4" Flange
Vent:	1/4" BSPM	1/4" BSPM	1/2" BSPM
Drain:	1/2" BSPM	1/2" BSPM	1" BSPM

Technical drawings for each housing showing dimensions, volume and weights available on request.

PED Status

Fluid Groups: Compliant with 97/23/EC
 Liquids Group 1 + 2
 Gas Group 2
 Marking: CE
 Exceptions: Group 1 liquids - Explosive
 ATEX: Compliant 94/9/EC, level CE Ex II 2 GD c X

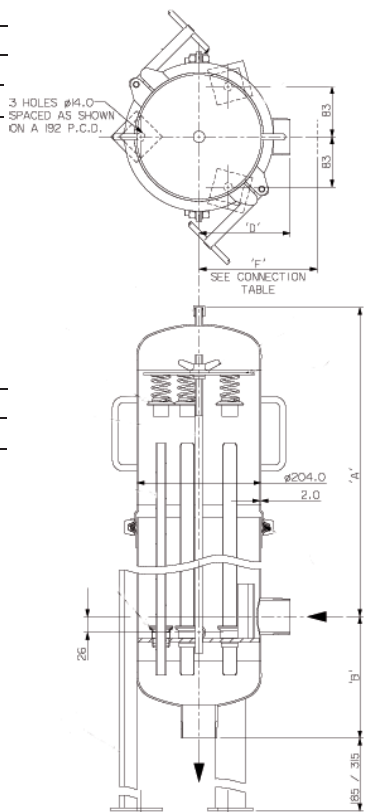

AMAZON FILTERS LTD.

ALBANY PARK ESTATE, FRIMLEY ROAD,
 CAMBERLEY, SURREY, GU16 7PG
 ENGLAND

Tel: +44 (0) 1276 670 600

Fax: +44 (0) 1276 670 101

Email: sales@amazonfilters.co.uk

Web: www.amazonfilters.co.uk



Certificate No. FM39584

Distributed by: