

# 71 SERIES

AMAZON

## HYGIENIC TANK VENT FILTER HOUSING



The **71 SERIES** Hygienic Vent filter cartridge housing is designed primarily for tank venting applications and is available with either 10 or 20" long cartridges.

The single common inlet / outlet connection is suited for direct mounting on to most sealed storage vessels, whilst the quick release seal-less Vee clamp closure allows for rapid filter changeouts.

These housings are ideal where free movement of clean air is of prime importance, and are designed for use with the naturally hydrophobic **SUPAPORE TP** PTFE membrane cartridge.

The **71 SERIES** housing will accept the full range of Amazon Single Open End code 7 cartridges ranging from 0.1 to 40µm with nominal lengths of 10 and 20".

### Product Features:

- Crevice free construction with hygienic single polished inlet/outlet port
- Quick release Vee clamp closure for ease of access - no seal required
- Lightweight easy lift dome
- No loose internals for trouble free operation
- ATEX compliant



## 71 SERIES FEATURES AND BENEFITS

- Bayonet lock code 7 cartridge fitting as standard for forward and reverse flow
- 316L construction for maximum corrosion resistance
- Every housing is etched with a serial number for full traceability
- Wide range of options available for the connection size and style, cartridge lengths and materials of construction
- Full housing customisation service available

71 SERIES

## TECHNICAL DATA

### Operating Conditions

Maximum Temperature: 110°C

### Materials of Construction

Body and Closure: 316L St. Steel  
Clamp: 304 St. Steel

### Finish

Vessel: Base 0.8Ra (clean side) with electropolish  
Dome internally pickled with external bright polish

### Connections

Inlet/Outlet: 1 1/2" Tri Clamp

Model	Dimensions					Volume (Litres)	Dry Weight
	A	B	C	D	E		
710117VN15L1VN	390	36	-	-	350	2.5	3.1
710127VN15L1VN	647	36	-	-	600	4.5	4.1

### PED Status:

Not Applicable

### ATEX:

Compliant 94/9/EC, level CE Ex II 2 GD c X

Technical drawings for each housing showing dimensions, volume and weights available on request.

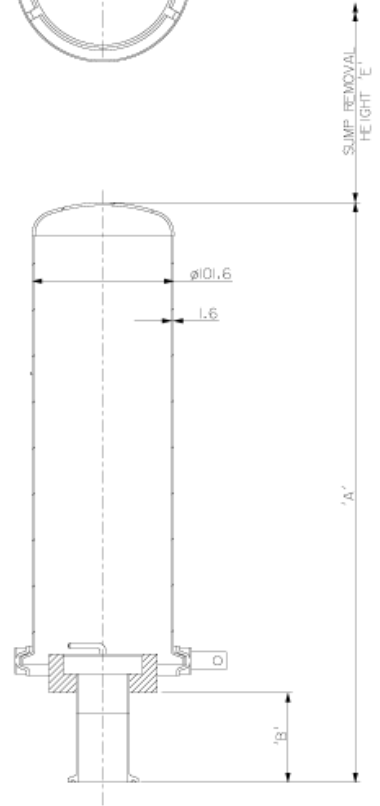
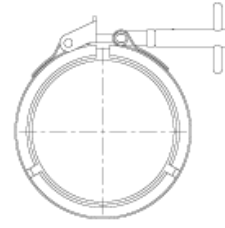

## AMAZON FILTERS LTD.

ALBANY PARK ESTATE, FRIMLEY ROAD,  
CAMBERLEY, SURREY, GU16 7PG  
ENGLAND

Tel: +44 (0) 1276 670 600

Fax: +44 (0) 1276 670 101

Email: [sales@amazonfilters.co.uk](mailto:sales@amazonfilters.co.uk)

Web: [www.amazonfilters.co.uk](http://www.amazonfilters.co.uk)



Certificate No. FM39584

Distributed by: