

73 SERIES

AMAZON

HYGENIC MULTI STACK FILTER HOUSING

The **73 SERIES** hygienic multi stack cartridge housing is available with 3, 5, 8 & 12 element stacks up to 30" long. The 'T' style configuration with dome cover is equipped with a Cast Vee clamp as standard for pressures ranging from 6 - 10 bar.g.

This leg mounted, free standing housing with domed cover is the ideal choice for all hygienic systems when using Single Open End plug in style cartridges. The simple lightweight dome allows full and easy access to the cartridges for rapid changeouts and the housings can be dismantled for full cleanowns.

Bolted closures are an option available for all models.

The **73 SERIES** housing will accept the full range of Amazon Single Open End industry standard cartridges ranging from 0.03 to 40µm with nominal lengths of 10, 20 and 30".

Product Features:

- 'T' style construction with a high specification hygienic finish with electropolish inside and out.
- Quick release Vee clamp closure for ease of access
- Designed to allow complete stripdown for ease of cleaning.
- No loose internals for trouble free operation.
- 4 vent options
- PED and ATEX compliant
- CE marked



73 SERIES FEATURES AND BENEFITS

- Standard single open end cartridge fitting, using either code 8 or Bayonet lock code 7 for forward and reverse flow
- 316L construction for maximum corrosion resistance.
- Every housing is etched with a serial number for full traceability.
- Wide range of options available for connection size and style, cartridge lengths and materials of construction
- Full certification available, PED and ATEX compliant, CE Marked

73 SERIES

TECHNICAL DATA

Operating Conditions

Maximum Pressure: Liquid: 10 bar.g
 Gas: 7303 - 7 bar.g
 7305 - 6 bar.g

Maximum Temperature: 110°C

Materials of Construction

Body and Closure: 316L St. Steel
 Clamp: 304 St. Steel

Finish

Vessel: 0.8Ra mechanically polished inside and out + final electropolish

Connections

Inlet/Outlet: 7303 - 1½" Tri Clamp
 7305 - 2" Tri Clamp

Model	Dimensions					Volume (Litres)	Dry Weight
	A	B	C	D	E		
730317AF15L1PS	643	176	-	323	400	11.4	18.2
730327AF15L1PS	897	176	-	323	650	19.4	21.2
730337AF15L1PS	1151	176	-	323	900	27.4	24.2

Model	Dimensions					Volume (Litres)	Dry Weight
	A	B	C	D	E		
730517AF20L1PS	645	150	-	350	350	14.2	19.0
730527AF20L1PS	899	150	-	350	600	23.3	22.5
730537AF20L1PS	1153	150	-	350	850	32.4	26.0

PED Status:

Compliant 97/23/EC
 Gas Group 2
 Liquids Group 1 + 2

Marking:

CE

Exceptions:

Group 1 liquids - Explosive

ATEX:

Compliant 94/9/EC, level CE Ex II 2 GD c X

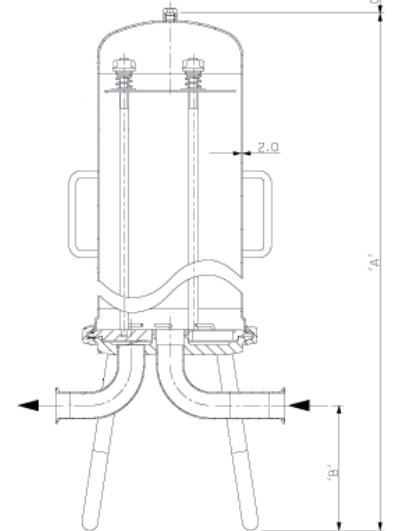
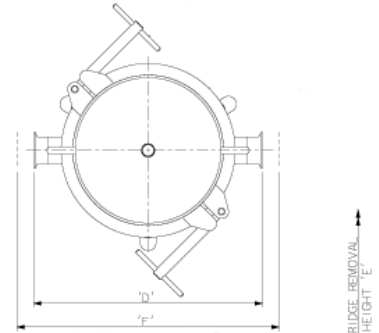

AMAZON FILTERS LTD.

ALBANY PARK ESTATE, FRIMLEY ROAD,
 CAMBERLEY, SURREY, GU16 7PG
 ENGLAND

Tel: +44 (0) 1276 670 600

Fax: +44 (0) 1276 670 101

Email: sales@amazonfilters.co.uk

Web: www.amazonfilters.co.uk



Certificate No. FM39584

Distributed by: